

Formatted: Font: 10 pt, Bold, Condensed by 0.15 pt

Balancing and Settlement Code

Code of Practice Two

**CODE OF PRACTICE FOR THE METERING OF CIRCUITS WITH A
RATED CAPACITY NOT EXCEEDING 100 MVA FOR SETTLEMENT
PURPOSES.**

Issue 5

Version 21.0~~Version 20.0~~

Formatted: Font: Times New Roman Bold, 14 pt, Bold

DATE: 07 March 2025~~29 February 2024~~

Formatted: Font: 10 pt, Bold

Formatted: Font: 10 pt, Bold, Condensed by 0.15 pt

Code of Practice Two

CODE OF PRACTICE FOR THE METERING OF CIRCUITS WITH A RATED CAPACITY NOT EXCEEDING 100 MVA FOR SETTLEMENT PURPOSES.

1. Reference is made to the Balancing and Settlement Code for the Electricity Industry in Great Britain and, in particular, to the definition of "Code of Practice" in Annex X-1 thereof.
2. This is Code of Practice Two, Issue 5, ~~Version 21.0~~~~Version 20.0~~.
3. This Code of Practice shall apply to Metering Systems comprising Metering Equipment that are subject to the requirements of Section L of the Balancing and Settlement Code.
4. This Code of Practice is effective from ~~07 March 2025~~~~29 February 2024~~.
5. This Code of Practice has been approved by the Panel.

Intellectual Property Rights, Copyright and Disclaimer

The copyright and other intellectual property rights in this document are vested in Elexon or appear with the consent of the copyright owner. These materials are made available for you for the purposes of your participation in the electricity industry. If you have an interest in the electricity industry, you may view, download, copy, distribute, modify, transmit, publish, sell or create derivative works (in whatever format) from this document or in other cases use for personal academic or other non-commercial purposes. All copyright and other proprietary notices contained in the document must be retained on any copy you make.

All other rights of the copyright owner not expressly dealt with above are reserved.

No representation, warranty or guarantee is made that the information in this document is accurate or complete. While care is taken in the collection and provision of this information, Elexon Limited shall not be liable for any errors, omissions,

Formatted: Font: 10 pt, Bold

misstatements or mistakes in any information or damages resulting from the use of this information or action taken in reliance on it.

AMENDMENT RECORD

Issue	Version	Date	Description of Changes	Changes Included	Mods/ Panel/ Committee Refs
Draft	0.03	18/3/93	Recommended to PEC; MSC		
1	1.00	15/4/93	Endorsed by PEC; CoP WG		
2	1.03	01/5/97	Amendments for 100kW Take-on; 1998 Programme		
3	1.05	1998 Operational Date	Amended following review by Expert Group and internally; 1998 Programme (C A Team)		
3	1.05	Code Effective Date ¹	Re-badging of Code of Practice Two for the implementation of the Balancing and Settlement Code; BSCCo (Elexon Limited)		Panel 16/11/00 (Paper 07/003)
3	2.0	BETTA Effective Date	Rebadging changes for the CVA Feb 05 Release; BSCCo	BETTA 6.3	
4	3.0	23/02/06	February 06 Release; BSCCo	CP1051	ISG55/020
4	4.0	06/11/08	November 08 Release; BSCCo	CP1232, CP1238	ISG88/01 SVG88/02
4	5.0	25/06/09	June 09 Release; BSCCo	CP1264	ISG94/01 SVG94/02
4	6.0	05/11/09	BSCCo	CP1289	ISG101/01
4	7.0	20/11/09	Modification P238; BSCCo		Panel 160/05
4	8.0	26/11/09	Modification P230; BSCCo		Panel 153/03
4	9.0	24/06/10	June 10 Release	CP1324	ISG111/03
4	10.0	23/02/12	February 12 Release	P266 CP1349	ISG130/08 ISG127/05
4	11.0	26/02/15	February 15 Release	CP1422	ISG163/01 SVG166/06
4	12.0	23/02/17	February 17 Release	CP1470	ISG185/02 SVG188/04
4	13.0	02/11/17	November 17 Release	CP1479 CP1485	Panel 264/11 ISG194/06
4	14.0	27/06/19	June 19 Release	CP1508	SVG213/04 ISG210/02
4	15.0	01/09/21	1 September 2021 Non-Standard Release	P420	P316/05
5	16.0	30/06/22	30 June Standard Release	CP1550, CP1527, CP1554	ISG248/07, SVG233/02, ISG231/01, ISG249/09, SVG251/09
5	17.0	17/11/22	17 November Special Release	P437	Panel 331/04

¹ "Code Effective Date" means the date of the Framework Agreement.

Issue	Version	Date	Description of Changes	Changes Included	Mods/ Panel/ Committee Refs
5	18.0	29/06/23	29 June Standard Release	CP1571 CP1572	SVG263/03 ISG261/04 SVG263/04 ISG261/05
5	19.0	02/11//23	02 November Standard Release	P453 CP1575	Panel 338/03 ISG266/04
5	20.0	29/02/24	29 February Standard Release	CP1586	SVG275/02 ISG273/03
<u>5</u>	<u>21.0</u>	<u>07/03/25</u>	<u>MHHS Release</u>	<u>MHHS</u>	

CODE OF PRACTICE FOR THE METERING OF CIRCUITS WITH A RATED CAPACITY NOT EXCEEDING 100MVA FOR SETTLEMENT PURPOSES.

FOREWORD	8
1. SCOPE	9
2. REFERENCES	10
3. DEFINITIONS AND INTERPRETATIONS	11
3.1 Active Energy *	11
3.2 Active Power *	11
3.3 Actual Metering Point ‡	11
3.4 Apparent Energy ‡	11
3.5 Apparent Power ‡	11
3.6 Boundary Point *	11
3.7 Central Data Collection Agent (CDCA) *	12
3.8 Communication Line ‡	12
3.9 CTN ‡	12
3.10 CVA †	12
3.11 CVA Customer †	12
3.12 Defined Metering Point ‡	12
3.13 Demand Period ‡	12
3.14 Demand Values ‡	12
3.15 Electricity *	13
3.16 Export †	13
3.17 Import †	13
3.18 Interrogation Unit ‡	13
3.19 Licensed Distribution System Operator (LDSO) *	13
3.20 Maximum Aggregated Capacity ‡	13
3.21 Meter *	13
3.22 Meter Register ‡	13
3.23 Metering Equipment *	14
3.24 Offshore Platform ‡	14
3.25 Offshore Power Park Module *	14
3.26 Outstation *	14
3.27 Outstation System ‡	14
3.28 PARh Meter ‡	14
3.29 Password ‡	14
3.30 PSTN ‡	14
3.31 Rated Measuring Current ‡	15
3.32 Reactive Energy *	15
3.33 Reactive Power *	15
3.34 Registrant *	15
3.35 Settlement Instation ‡	15
3.36 Single Line Diagram (SLD)	15
3.37 SVA †	15
3.38 SVA Customer *	15
3.39 SVA Meter Operator Agent *	15
3.40 Systems Connection Point *	16
3.41 UTC *	16
4. MEASUREMENT CRITERIA	16
4.1 Measured Quantities and Demand Values for Metering Systems Registered in CMRS	16
4.2 Measured Quantities and Demand Values for Metering Systems Registered in SMRS	17
4.3 Accuracy Requirements	18
5. METERING EQUIPMENT CRITERIA	20
5.1 Measurement Transformers	20
5.2 Testing Facilities	24

Formatted: Font: 10 pt, Bold, Condensed by 0.15 pt

5.3	Meters	24
5.4	Displays and Facilities for Registrant or Supplier Information	25
5.5	Outstation	26
5.6	Communications	29
5.7	Sealing	31
5.8	Single Line Diagram	31
6.	ASSOCIATED FACILITIES	33
6.1	Interrogation Unit	33
6.2	Additional Features	33
7.	ACCESS TO DATA	33
APPENDIX A: DEFINED METERING POINTS		34
APPENDIX B: LABELLING OF METERS FOR IMPORT AND EXPORT		36
APPENDIX C: FUSING		40
APPENDIX D: PASSWORDS		42
APPENDIX E: GUIDANCE FOR THE USE OF MULTI CORE METERING CABLES		43
APPENDIX F: GUIDANCE FOR THE COMMUNICATION ARRANGEMENTS FOR METERING SYSTEMS LOCATED OFFSHORE AT OFFSHORE POWER PARK MODULES		44
APPENDIX G: GUIDANCE FOR THE USE OF BUSBAR VOLTAGE TRANSFORMERS		47
FOREWORD		7
1.	SCOPE	8
2.	REFERENCES	9
3.	DEFINITIONS AND INTERPRETATIONS	10
3.1	Active Energy *	10
3.2	Active Power *	10
3.3	Actual Metering Point ‡	10
3.4	Apparent Energy ‡	10
3.5	Apparent Power ‡	10
3.6	Boundary Point *	10
3.7	Central Data Collection Agent (CDCA) *	11
3.8	Communication Line ‡	11
3.9	CTN ‡	11
3.10	CVA †	11
3.11	CVA Customer †	11
3.12	Defined Metering Point ‡	11
3.13	Demand Period ‡	11
3.14	Demand Values ‡	11
3.15	Electricity *	11
3.16	Export †	12
3.17	Import †	12
3.18	Interrogation Unit ‡	12
3.19	Licensed Distribution System Operator (LDSO) *	12
3.20	Maximum Aggregated Capacity ‡	12
3.21	Meter *	12
3.22	Meter Register ‡	12
3.23	Metering Equipment *	12
3.24	Offshore Platform ‡	13
3.25	Offshore Power Park Module *	13
3.26	Outstation *	13
3.27	Outstation System ‡	13
3.28	PARh Meter ‡	13
3.29	Password ‡	13
3.30	PSTN ‡	13
3.31	Rated Measuring Current ‡	13

Formatted: Default Paragraph Font, Check spelling and grammar

Formatted: Default Paragraph Font, Check spelling and grammar

Formatted: Default Paragraph Font, Check spelling and grammar

Formatted: Default Paragraph Font, Check spelling and grammar

Formatted: Default Paragraph Font, Check spelling and grammar

Formatted: Default Paragraph Font, Check spelling and grammar

Formatted: Default Paragraph Font, Check spelling and grammar

Formatted: Default Paragraph Font, Check spelling and grammar

Formatted: Default Paragraph Font, Check spelling and grammar

Formatted: Default Paragraph Font, Check spelling and grammar

Formatted: Default Paragraph Font, Check spelling and grammar

Formatted: Default Paragraph Font, Check spelling and grammar

Formatted: Default Paragraph Font, Check spelling and grammar

Formatted: Default Paragraph Font, Check spelling and grammar

Formatted

Formatted

Formatted

Formatted

Formatted

Formatted

Formatted

Formatted

Formatted

Formatted

Formatted

Formatted

Formatted

Formatted

Formatted

Formatted

Formatted

Formatted

Formatted

Formatted

Formatted

Formatted

Formatted

Formatted

Formatted: Font: 10 pt, Bold

3.32	Reactive Energy *	14
3.33	Reactive Power *	14
3.34	Registrant *	14
3.35	Settlement Instation ‡	14
3.36	Single Line Diagram (SLD)	14
3.37	SVA †	14
3.38	SVA Customer *	14
3.39	SVA Meter Operator Agent *	14
3.40	Systems Connection Point *	14
3.41	UTC *	15
4.	MEASUREMENT CRITERIA	15
4.1	Measured Quantities and Demand Values for Metering Systems Registered in CMRS	15
4.2	Measured Quantities and Demand Values for Metering Systems Registered in SMRS	15
4.3	Accuracy Requirements	17
5.	METERING EQUIPMENT CRITERIA	19
5.1	Measurement Transformers	19
5.2	Testing Facilities	23
5.3	Meters	23
5.4	Displays and Facilities for Registrant or Supplier Information	24
5.5	Outstation	25
5.6	Communications	28
5.7	Sealing	30
5.8	Single Line Diagram	30
6.	ASSOCIATED FACILITIES	32
6.1	Interrogation Unit	32
6.2	Additional Features	32
7.	ACCESS TO DATA	32
	APPENDIX A: DEFINED METERING POINTS	33
	APPENDIX B: LABELLING OF METERS FOR IMPORT AND EXPORT	35
	APPENDIX C: FUSING	39
	APPENDIX D: PASSWORDS	41
	APPENDIX E: GUIDANCE FOR THE USE OF MULTI CORE METERING CABLES	42
	APPENDIX F: GUIDANCE FOR THE COMMUNICATION ARRANGEMENTS FOR METERING SYSTEMS LOCATED OFFSHORE AT OFFSHORE POWER PARK MODULES	43
	APPENDIX G: GUIDANCE FOR THE USE OF BUSBAR VOLTAGE TRANSFORMERS	46

Formatted: Font: 10 pt, Bold, Condensed by 0.15 pt

Formatted: Default Paragraph Font, Check spelling and grammar

Formatted: Default Paragraph Font, Check spelling and grammar

Formatted: Default Paragraph Font, Check spelling and grammar

Formatted: Default Paragraph Font, Check spelling and grammar

Formatted: Default Paragraph Font, Check spelling and grammar

Formatted: Default Paragraph Font, Check spelling and grammar

Formatted: Default Paragraph Font, Check spelling and grammar

Formatted: Default Paragraph Font, Check spelling and grammar

Formatted: Default Paragraph Font, Check spelling and grammar

Formatted: Default Paragraph Font, Check spelling and grammar

Formatted: Default Paragraph Font, Check spelling and grammar

Formatted: Default Paragraph Font, Check spelling and grammar

Formatted: Default Paragraph Font, Check spelling and grammar

Formatted: Default Paragraph Font, Check spelling and grammar

Formatted: Default Paragraph Font, Check spelling and grammar

Formatted: Default Paragraph Font, Check spelling and grammar

Formatted

Formatted

Formatted

Formatted

Formatted

Formatted

Formatted

Formatted

Formatted

Formatted

Formatted

Formatted

Formatted

Formatted

Formatted

Formatted

Formatted: Font: 10 pt, Bold

FOREWORD

This Code of Practice defines the minimum requirements for the Metering Equipment required for the measurement and recording of electricity transfers occurring at the relevant Defined Metering Points (DMPs) where the rated circuit capacity, at the Actual Metering Points (AMPs) does not exceed 100MVA.

For the purpose of this Code of Practice the rated circuit capacity in MVA shall be determined by the lowest rated primary plant (e.g. transformer rating, line rating, etc) of the circuit (this does not include the capacity of the load or generation connected to that circuit) at the AMP. The Metering Equipment provision and accuracy requirements shall anticipate any future up-rating consistent with the installed primary plant. The primary plant maximum continuous ratings shall be used in this assessment.

For the purpose of this Code of Practice, the use of summation current transformers shall not be permitted. The use of interposing current transformers is permitted provided the overall Metering System accuracy is maintained.

Where a material change to a Metering System takes place, then this Metering System must be modified to comply with the most recent version of this Code of Practice. Changes to a Metering System are considered to be material where they constitute a change to:

- i. Switchgear containing measurement transformers; and/or
- ii. The primary plant associated with the Metering System i.e. the measurement transformers.

Where a Metering Dispensation applies, and where the AMP is not at the DMP, a material change affecting the DMP may not necessarily affect the Metering System at the AMP.

BSCCo shall retain copies of, inter alia, the Code of Practice together with copies of all documents referred to in them, in accordance with the provisions of the Balancing and Settlement Code (the Code).

1. SCOPE

This Code of Practice states the practices that shall be employed, and the facilities that shall be provided for the measurement and recording of the quantities required for Settlement purposes on each² circuit where the rated capacity, at the AMP, does not exceed 100MVA.

For the avoidance of doubt, where the DMP, as set out in Appendix A, and the AMP do not coincide, the relevant Code of Practice is associated with the circuit that is being metered (located at the AMP), as opposed to the relevant Code of Practice associated with the circuit at the DMP.

It derives force from the Code, and in particular the metering provisions (Section L), to which reference should be made. It should also be read in conjunction with any relevant BSC Procedures.

Metering Equipment that meets the requirements of this Code of Practice is also applicable where the Registrant is required by its Supply Licence (and as referenced in Section L 3.2.6) to install Metering Equipment that is capable of providing measured electricity consumption data for multiple periods (at least half hourly) and providing the Registrant with remote access to such data.

This Code of Practice does not contain the calibration, testing and commissioning requirements for Metering Equipment used for Settlement purposes. These requirements are detailed in Code of Practice Four - "Code of Practice for Calibration, Testing and Commissioning Requirements for Metering Equipment for Settlement Purposes".

Metering Dispensations from the requirements of this Code of Practice may be sought in accordance with the Code and BSCP32.

Meters and Outstations referred to in this Code of Practice shall only achieve successful compliance in respect of any testing detailed in this Code of Practice if the requirements set out in accordance with BSCP601 are also observed and successfully completed or a valid Metering Dispensation has been granted covering any departure from the requirements as detailed in this Code of Practice.

In the event of an inconsistency between the provisions of this Code of Practice and the Code, the provisions of the Code shall prevail.

² Subject to the use of busbar voltage transformers allowed under clause 5.1.2.

2. REFERENCES

The following documents are referred to in the text³, except in relation to measurement transformers where one of the conditions, set out in Section 5.1, is met -

BS EN 50470 – 3	Electricity metering equipment (a.c.) - Part 3: Particular requirements – Static meters for active energy (class indexes A, B and C)
BS EN/IEC 61869-4	Instrument transformers. Part 4: Additional requirements for combined transformers
BS EN/IEC 62053-11	Electricity metering equipment (a.c.). Particular requirements. Electromechanical meters for active energy (classes 0.5, 1 and 2)
BS EN/IEC 62053-22	Electricity metering equipment Particular requirements. Part 22: Static meters for AC active energy (classes 0.1S, 0.2S and 0.5S)
BS EN/IEC 62053-23	Electricity metering equipment Particular requirements. Part 23: Static meters for reactive energy (classes 2 and 3)
BS EN/IEC 62056-21	Electricity metering. Data exchange for meter reading, tariff and load control. Direct local data exchange
BS EN/IEC 61869-2	Instrument transformers. Part 2: Additional requirements for current transformers
BS EN/IEC 61869-3	Instrument transformers. Part 3: Additional requirements for inductive voltage transformers
Balancing and Settlement Code	Definitions, Section X; Annex X-1 and Section L and BSC Procedures
Code of Practice Four	Code of Practice for Calibration, Testing and Commissioning Requirements for Metering Equipment for Settlement Purposes
BSC Procedures	BSCP06, BSCP32, BSCP75, BSCP502, BSCP601
Electricity Act 1989	Schedule 7 as amended by Schedule 1 to the Competition and Services (Utilities) Act 1992.
Retail Energy Code or REC	As per the term “Retail Energy Code” in each Supply Licence granted under Section 6 of the Electricity Act 1989.

³ Metering Equipment should be tested and stamped to the latest iteration of the applicable standard named in this document at the time of initial registration.

REC Metering Operations Schedule Schedule 14 of the REC on obligations in respect of metering operations.

3. DEFINITIONS AND INTERPRETATIONS

Save as otherwise expressly provided herein, words and expressions used in this Code of Practice shall have the meanings attributed to them in the Code and are included for the purpose of clarification.

Note: * indicates definitions in the Code.

Note: † indicates definitions which supplement or complement those in the Code.

Note: ‡ indicates definitions specific to this Code of Practice

3.1 Active Energy *

Active Energy means the electrical energy produced, flowing or supplied by an electrical circuit during a time interval, being the integral with respect to time of the instantaneous Active Power, measured in units of watt-hours or standard multiples thereof.

3.2 Active Power *

Active Power means the product of voltage and the in-phase component of alternating current measured in units of watts and standard multiples thereof, that is:-

1,000 Watts = 1 kW

1,000 kW = 1 MW

3.3 Actual Metering Point ‡

Actual Metering Point means the physical location at which electricity is metered.

3.4 Apparent Energy ‡

Apparent Energy means the integral with respect to time of the Apparent Power.

3.5 Apparent Power ‡

Apparent Power means the product of voltage and current measured in units of volt-amperes and standard multiples thereof, that is:-

1,000 VA = 1 kVA

1,000 kVA = 1 MVA

3.6 Boundary Point *

Boundary Point means a point at which any Plant or Apparatus not forming part of the Total System is connected to the Total System.

3.7 Central Data Collection Agent (CDCA) *

Central Data Collection Agent means the BSC Agent for Central Data Collection in accordance with Section E of the Code.

3.8 Communication Line ‡

[\[P478\]](#) Communication Line means a line or link whose components are dedicated to a single Outstation System. A Communication Line shall be identified by a unique number, e.g. CTN line number 123, PSTN line number 321 or IP address 555. Communication Lines may comprise electrical circuits, optical fibres, radio links, or any other permitted media which allows data to be collected remotely on demand by the CDCA ~~or a~~ Data Collector or Data Service, as the case may be, or Meter Operator using an approved protocol.

3.9 CTN ‡

CTN means the Electricity Supply Industry (ESI) corporate telephone network.

3.10 CVA †

CVA means "Central Volume Allocation".

3.11 CVA Customer †

CVA Customer means any customer, receiving electricity directly from the Transmission System, irrespective of from whom it is supplied.

3.12 Defined Metering Point ‡

Defined Metering Point means the physical location at which the overall accuracy requirements as stated in this Code of Practice are to be met. The Defined Metering Points are identified in Appendix A.

3.13 Demand Period ‡

Demand Period means the period over which Active Energy, Reactive Energy or Apparent Energy are integrated to produce Demand Values. For Settlement purposes, each Demand Period shall be of 30 minutes duration, one of which shall finish at 24:00 hours.

3.14 Demand Values ‡

Demand Values means, expressed in MW, Mvar or MVA, twice the value of MWh, Mvarh or MVAh recorded during any Demand Period⁴. The Demand Values are half hour demands and these are identified by the time of the end of the Demand Period.

⁴ Please note that these Demand Values are for use with CVA Metering Systems. SVA Metering Systems shall use units a factor of 103 smaller than CVA e.g. kW rather than MW.

3.15 Electricity *

"electricity" means Active Energy and Reactive Energy.

3.16 Export †

Export means, for the purposes of this Code of Practice, an electricity flow as indicated in Figure 1 of Appendix B.

3.17 Import †

Import means, for the purposes of this Code of Practice, an electricity flow as indicated in Figure 1 of Appendix B.

3.18 Interrogation Unit ‡

Interrogation Unit means a Hand Held Unit "HHU" (also known as Local Interrogation Unit "LIU") or portable computer which can enter Outstation parameters and extract information from the Outstation and store this for later retrieval.

3.19 Licensed Distribution System Operator (LDSO) *

Licensed Distribution System Operator means a Party which holds a Distribution Licence in respect of distribution activities in Great Britain, acting in that capacity.

3.20 Maximum Aggregated Capacity ‡

The maximum aggregated capacity for multiple circuits shall be determined for:-

- (i) Generator circuits, by the summation of the capacities of the lowest primary plant rating for each circuit.
- (ii) Network or customer circuits all of equal rating, by multiplying the lowest primary plant rating of one circuit by one less than the number of circuits involved, e.g. number of circuits (n) = 3, factor = n - 1 = 2.
- (iii) Network or customer circuits of different ratings, (all of which must be under 100 MVA) by summation of the lowest plant rating for each circuit ignoring the highest rated circuit e.g. 3 circuits rated at 45 MVA, 40 MVA, 35 MVA, rating = 75 MVA.

3.21 Meter *

Meter means a device for measuring Active Energy and/or Reactive Energy.

3.22 Meter Register ‡

Meter Register means a device, normally associated with a Meter, from which it is possible to obtain a reading of the amount of Active Energy, or the amount of Reactive Energy that has been supplied by a circuit.

3.23 Metering Equipment *

Metering Equipment means Meters, measurement transformers (voltage, current and combination units), metering protection equipment including alarms, circuitry, their associated Communications Equipment and Outstations, and wiring.

3.24 Offshore Platform ‡

Has the meaning given to that term in the Grid Code.

3.25 Offshore Power Park Module *

Has the meaning given to that term in the Grid Code.

3.26 Outstation *

[P478] Outstation means equipment which receives and stores data from a Meter(s), for the purposes, inter-alia, of transfer of that metering data to the CDCA ~~or~~ Data Collector or Data Service, as the case may be, and which may perform some processing before such transfer and may be in one or more separate units or may be integral with the Meter.

3.27 Outstation System ‡

Outstation System means one or more Outstations linked to a single communication line.

3.28 PARh Meter ‡

PARh Meter means a phase-advanced reactive hour (PARh) Meter which is used for obtaining Import and Export Reactive Energy from one integrating Meter. The Reactive Energy Demand values shall be calculated using a formula involving the PARh Meter and the associated Active Energy Meter Demand Values.

3.29 Password ‡

For Meters with integral Outstations: 'Password' means a string of characters of length no less than six characters and no more than twelve characters, where each character is a case insensitive or sensitive alpha character (A to Z) or a digit (0 to 9) or the underscore character (_). Passwords must have a minimum of 2,000,000 combinations, for example six characters if composed of any alphanumeric characters or eight characters if composed only of hexadecimal characters (0 to F). The characters of a hexadecimal password must be in upper case.

For separate Outstations: a Password may be described as above for integral Outstations or a single password of any format⁵.

3.30 PSTN ‡

PSTN means the public switched telephone network.

⁵ Meters separate from their Outstation and capable of external communications should have the same password requirements as for separate Outstations.

3.31 Rated Measuring Current ‡

Rated Measuring Current means the rated primary current of the current transformers in primary plant used for the purposes of measurement.

3.32 Reactive Energy *

Reactive Energy means the integral with respect to time of the Reactive Power and for the purpose of the Code, is comprised of Active Export Related Reactive Energy and Active Import Related Reactive Energy.

3.33 Reactive Power *

Reactive Power means the product of voltage and current and the sine of the phase angle between them measured in units of volt-amperes reactive and standard multiples thereof.

3.34 Registrant *

Registrant means in relation to a Metering System, the person for the time being registered in CMRS or (as the case may be) SMRS in respect of that Metering System pursuant to Section K of the Balancing and Settlement Code.

3.35 Settlement Instation ‡

[\[P478\]](#) Settlement Instation means a computer based system which collects or receives data on a routine basis from selected Outstation Systems by as Data Collector [or Data Service as the case may be](#).

3.36 Single Line Diagram (SLD)

SLD means simplified notation for representing a three-phase power system that must show the location of all relevant circuits and the Metering Equipment associated with a site.

3.37 SVA †

SVA means "Supplier Volume Allocation".

3.38 SVA Customer *

SVA Customer means a person to whom electrical power is provided, whether or not that person is the provider of that electrical power; and where that electrical power is measured by a SVA Metering System.

3.39 SVA Meter Operator Agent *

SVA Meter Operator Agent has the meaning given to the term "Metering Equipment Manager" in the REC, to the extent that the Metering Equipment Manager has been appointed by a Supplier.

3.40 Systems Connection Point *

Systems Connection Point means a point of connection (whether consisting of one or more circuits) between two or more Systems excluding:

- a) a point of connection between Distribution Systems in the same GSP Group; and
- b) a point of connection between Offshore Transmission System User Assets and the Transmission System;

3.41 UTC *

UTC means Co-ordinated Universal Time which bears the same meaning as in the document Standard Frequency and Time Signal Emission, International Telecommunication Union - RTF.460 (ISBN92-61-05311-4) (colloquially referred to as Rugby Time).

4. MEASUREMENT CRITERIA

The following measured quantities and Demand Values are for use with CVA Metering Systems.

4.1 Measured Quantities and Demand Values for Metering Systems Registered in CMRS

4.1.1 Measured Quantities

For each separate circuit the following energy measurements are required for Settlement purposes:

- (i) Import MWh *
- (ii) Export MWh *
- (iii) Import Mvarh
- (iv) Export Mvarh

4.1.2 Demand Values

For each Demand Period for each circuit the following Demand Values shall be provided:

- (i) Import MW *
- (ii) Export MW *
- (iii) Import Mvar
- (iv) Export Mvar

- * Import or Export metering need only be installed where a Party requires this measurement to meet system or plant conditions.

4.2 Measured Quantities and Demand Values for Metering Systems Registered in SMRS

SVA Metering Systems shall use units a factor of 10^3 smaller than CVA i.e. kWh rather than MWh.

4.2.1 Measured Quantities

For each separate circuit the following energy measurements are required for Settlement purposes:-

- (i) Import kWh *
- (ii) Export kWh *
- (iii) Active Import related Import kvarh
- (iv) Active Import related Export kvarh
- (v) Active Export related Import kvarh
- (vi) Active Export related Export kvarh

4.2.2 Demand Values

For each Demand Period for each circuit the following Demand Values shall be provided:-

- (i) Import kW *
- (ii) Export kW *
- (iii) Active Import related Import kvar
- (iv) Active Import related Export kvar
- (v) Active Export related Import kvar
- (vi) Active Export related Export kvar

- * Import or Export metering need only be installed where a Party requires this measurement to meet system or plant conditions. However, both Import and Export reactive measurements shall be provided for each Active measurement.

4.3 Accuracy Requirements

4.3.1 Overall Accuracy

The overall accuracy of the energy measurements at or referred to the Defined Metering Point shall at all times be within the limits of error as shown:-

(i) Active Energy

CONDITION	LIMIT OF ERRORS AT STATED SYSTEM POWER FACTOR	
	Power Factor	Limits of Error
Current expressed as a percentage of Rated Measuring Current		
120% to 10% inclusive	1	± 1.0%
Below 10% to 5%	1	± 1.5%
Below 5% to 1%	1	± 2.5%
120% to 10% inclusive	0.5 lag and 0.8 lead	± 2.0%

(ii) Reactive Energy

CONDITION	LIMIT OF ERRORS AT STATED SYSTEM POWER FACTOR	
	Power Factor	Limits of Error
Current expressed as a percentage of Rated Measuring Current		
120% to 10% inclusive	Zero	± 4.0%
120% to 20% inclusive	0.866 lag and 0.866 lead	± 5.0%

These limits of error for both (i) and (ii) above shall apply at the reference conditions defined in the appropriate Meter specification.

Where Plant operating conditions mean the percentage of Rated Measuring Current and/or system power factor are outside the combinations specified in the overall accuracy tables for (i) and (ii), care must be taken to ensure the actual errors are considered at those Plant operating conditions. For example, where a site which normally Exports large quantities of Active Energy, but, when not generating, Imports Active Energy at a percentage of Rated Measuring Current below 1%, irrespective of the power factor. This could also mean the Active Energy Meter and the Reactive Energy Meter are inaccurate. If necessary, designers should take measures, wherever

reasonably practicable, to ensure the actual errors are within the nearest limits of error specified in the relevant overall accuracy table, by for example, the use of more accurate Metering Equipment than specified in this Code of Practice or the selection of a suitable current transformer ratio closely aligned to the maximum primary current for the relevant circuit.

Evidence to verify that these overall accuracy requirements are met shall be available for inspection by either the Panel or the Technical Assurance Agent.

4.3.2 Compensation for Measurement Transformer Error

To achieve the overall accuracy requirements it may be necessary to compensate Meters for the errors of the measurement transformers and the associated leads to the Meters. Values of the compensation shall be recorded and evidence to justify the compensation criteria, including wherever possible test certificates, shall be available for inspection by either the Panel or the Technical Assurance Agent.

4.3.3 Compensation for Power Transformer and Line Losses

Subject to Appendix A paragraph 5(ii), where the AMP and the DMP do not coincide and accuracy compensation for power transformer and/or cable/line and/or busbar losses is required to be applied to meet the overall accuracy limits of error requirements in paragraph 4.3.1 at the DMP then a Metering Dispensation shall be applied for.

Where the AMP and DMP do not coincide, but no accuracy compensation for power transformer and/or cable/line and/or busbar losses is required to be applied to meet overall accuracy limits of error at the DMP (i.e. the distance between the AMP and DMP does not introduce a large enough error to cause the Metering System's overall accuracy to be outside of the limits of error detailed in paragraph 4.3.1 of this relevant Code of Practice), then a Metering Dispensation shall not be required. The Registrant shall ensure that values of the overall accuracy calculation shall be recorded and evidence to justify no accuracy compensation being required, including wherever possible test certificates, shall be available for inspection by the Panel or Technical Assurance Agent.

Where Appendix A paragraph 5(ii) applies a Metering Dispensation shall not be required and accuracy compensation for power transformer and/or cable/line and/or busbar losses (for the purpose of Section K1.1.6 of the Code) shall, where necessary, be applied to meet the overall accuracy limits of error required at the DMP.

The accuracy compensation may be achieved in the Metering Equipment and in this event the required to be or applied values shall be validated in accordance with BSCP32 'Metering Dispensations' and recorded. Supporting evidence to justify the accuracy compensation criteria shall be available for inspection by either the Panel or the Technical Assurance Agent.

Alternatively, the accuracy compensation may be provided or applied in the software of the relevant data aggregation system used for Settlement purposes. In this event the factors shall be validated in accordance with BSCP32 'Metering Dispensations', passed to the appropriate agency and evidence to justify the accuracy compensation criteria shall be made available for inspection by either the Panel or the Technical Assurance Agent. Where the AMP associated with a Settlement Metering System, is below the

AMP associated with another Settlement Metering System, a differencing metering arrangement shall be used. For Metering Systems registered in CMRS this shall be done in accordance with BSCP75 'Registration of Meter Aggregation Rules For Volume Allocation Units'. For Metering Systems registered in SMRS this shall be done in accordance with the Metering Operations Schedule of the Retail Energy Code (REC) and BSCP502 'Half Hourly Data Collection for SVA Metering Systems Registered in SMRS', via a Complex Site Supplementary Information Form⁶.

5. METERING EQUIPMENT CRITERIA

Although for clarity this Code of Practice identifies separate items of equipment, nothing in it prevents such items being combined to perform the same task provided the requirements of this Code of Practice are met.

Metering Equipment other than outdoor measurement transformers shall be accommodated in a clean and dry environment.

5.1 Measurement Transformers

All measurement transformers shall be of a wound construction.

For each circuit² current transformers (CT) and voltage transformers (VT) shall meet the requirements set out in clauses 5.1.1 and 5.1.2.

The number of CTs provided shall be equal to or one less than the number of primary system conductors. These include the neutral conductor and/or earth conductor, where system configuration enable the flow of zero sequence energy. Consideration shall be given as to whether a VT neutral is required to be provided, depending on the number of CTs provided.

Where a measurement transformer has been tested and stamped to an iteration of the applicable BS EN/IEC standard and that differs from the version referenced in this Code of Practice (i.e. BS EN/IEC 61869-2; BS EN/IEC 61869-3; BS EN/IEC 61869-4) measurement transformers may still be used providing the requirements in clauses 4.3.1 and 5.1.3 are met and if one of the following conditions is met:

- All measurement transformers purchased post implementation⁷ of the latest applicable BS EN/IEC standard should be manufactured in accordance with that version of the BS EN/IEC standard that has superseded the version of the BS EN/IEC standard referenced in this Code of Practice (i.e. BS EN/IEC 61869-2; BS EN/IEC 61869-3; BS EN/IEC 61869-4). **This is only for measurement transformers where the same accuracy class is available and limits of error and phase displacement have not changed from the BS EN/IEC standard referenced in this Code of Practice (i.e. BS EN/IEC 61869-2; BS EN/IEC 61869-3; BS EN/IEC 61869-4); or**

⁶ Refer to 'Guide to Complex Sites' section in [BSCP502](#).

⁷ This condition is in effect until this Code of Practice has been updated to reference the latest versions of the applicable BS EN/IEC standard.

- All measurement transformers purchased prior to the implementation⁸ of the latest version of the applicable BS EN/IEC standard referenced in this Code of Practice (i.e. BS EN/IEC 61869-2; BS EN/IEC 61869-3; BS EN/IEC 61869-4) should be in accordance with the previous version of the applicable BS EN/IEC standard that the latest version has superseded. **This is only for stocks of measurement transformers held to be used up and does not allow measurement transformers compliant with an older version of a BS EN/IEC standard where the same accuracy class is not available or limits of error and phase displacement have changed to be used.**

Additionally, where a combined unit measurement transformer (VT & CT) is provided the 'Tests for Accuracy' as covered in BS EN/IEC 61869-4 covering mutual influence effects shall be met.

For Metering Systems that represent low burdens on measurement transformers, consideration shall be given as to whether that operating burden is within the operating range of the measurement transformers. In such cases, it may be necessary to add additional burden.

Guidance for the use of multi core cables is provided in Appendix E.

5.1.1 Current Transformers

A dedicated set of current transformers in accordance with BS EN/IEC 61869-2 and with a minimum standard of accuracy to class 0.2S (irrespective of the secondary current rating of the CTs) shall be provided solely for the Settlement metering of each circuit. No other burden⁹ shall be connected to this dedicated set of current transformers. The main Meter shall always be connected to this dedicated set of current transformers. The check Meter may also be connected to this dedicated set of current transformers.

The rated primary current value chosen for the current transformer shall be of a suitable value to ensure, under all running conditions wherever reasonably practicable, that the Rated Measuring Current (expressed as a percentage) does not fall below 1% or exceed 120%.

Additional burden can be added to the current transformers supplying the main Meters so long as it is only for the purpose of ensuring that overall accuracy of the energy measurements is within the limits of error in paragraph 4.3.1, for example by bringing the total burden within the value from 25 % to 100 % of the rated output that the limits of ratio error and phase displacement are specified for in BS EN/IEC 61869-2.

Alternatively the check Meter may be connected to another set of current transformers which shall be in accordance with BS EN/IEC 61869-2 and with a minimum standard of accuracy to class 0.2S. Other burdens including additional burden that can be added for the purpose of ensuring that overall accuracy of the energy measurements is within the limits of error in paragraph 4.3.1 by bringing the total burden within the value from 25 %

⁸ This condition is in effect from when this Code of Practice has been updated to reference the latest versions of the applicable BS EN/IEC standard.

⁹ With the exception of any burden added to ensure that the operating burden is within the operating range of the measurement transformers

to 100 % of the rated output that the limits of ratio error and phase displacement that are specified in BS EN/IEC 61869-2, may be connected to this other set of current transformers provided that the Panel or Technical Assurance Agent is notified and that the overall accuracy requirements in clause 4.3.1 are met

Evidence of the value of the additional burden shall be made available for inspection by the Panel. The additional burden shall not be modified without prior notification to the Panel, and evidence of the value of the modified additional burden shall be available for inspection by either the Panel or Technical Assurance Agent.

CT test certificates showing errors at the overall working burden or at burdens which enable the working burden errors to be calculated shall be available for inspection by either the Panel or the Technical Assurance Agent.

The total burden on each current transformer shall not exceed the rated burden of such CT.

5.1.2 Voltage Transformers

There are two options for the provision of voltage transformers (busbar voltage transformers shall only be permitted where the conditions for their use are met):

1. Voltage transformer primary windings shall be connected to the circuit being measured for Settlement purposes and a dedicated secondary winding shall be provided for the main and check metering.

Additional burden can be added to the voltage transformers supplying the Meters so long as it is only for the purpose of ensuring that overall accuracy of the energy measurements is within the limits of error in paragraph 4.3.1, for example by bringing the total burden within the value from 25 % to 100 % of the rated output that the limits of ratio error and phase displacement that are specified for in BS EN/IEC 61869-3.

Where a voltage transformer has other secondary windings, these may be used for the check metering of that circuit and for other purposes, and additional burden can be added for the purpose of ensuring that overall accuracy of the energy measurements is within the limits of error in paragraph 4.3.1, for example by bringing the total burden within the value from 25% to 100% of rated output that the limits of ratio error and phase displacement are specified for in BS EN/IEC 61869-3, provided the overall accuracy requirements in clause 4.3.1 are met; or

2. Voltage transformer primary windings shall be connected to a busbar that is common to multiple circuits that are being measured for Settlement purposes. The multiple circuits being measured, by the associated current transformers for those circuits, must be connected to the same busbar, which cannot be electrically split, and only where the multiple circuits are connected to that busbar at the same voltage level as it is at the DMP. A voltage transformer with a dedicated secondary winding shall be provided for all of the main metering, and a second voltage transformer with a dedicated secondary winding shall be provided for all of the check metering.

Where busbars can be, or are, electrically separated, each busbar section must have a set of voltage transformers each (i.e. a voltage transformer with a dedicated secondary winding shall be provided for all of the main metering and a second voltage transformer with a dedicated secondary winding for all of the check metering, for the circuits connected to that busbar section).

Additional burden can be added to the voltage transformers supplying the Meters so long as it is only for the purpose of ensuring that overall accuracy of the energy measurements is within the limits of error in paragraph 4.3.1, for example by bringing the total burden within the value from 25 % to 100 % of the rated output that the limits of ratio error and phase displacement that are specified for in BS EN/IEC 61869-3.

Where a busbar voltage transformer has been provided for multiple circuits, that are being measured for Settlement purposes, by the associated current transformers for those circuits, and it has other secondary windings, these may be used for other purposes, provided the overall accuracy requirements in clause 4.3.1 are met.

Appendix G shows some examples of arrangements for busbar voltage transformers.

Each voltage transformer secondary winding shall be in accordance with BS EN/IEC 61869-3 and with a minimum standard of accuracy to Class 0.5. Evidence of the value of any additional burden shall be made available for inspection by the Panel or Technical Assurance Agent. Any additional burden shall not be modified without prior notification to the Panel, and evidence of the value of the modified additional burden shall be available for inspection by either the Panel or the Technical Assurance Agent.

A VT test certificate(s) showing errors at the overall working burden(s) or at burdens which enable the working burden errors to be calculated shall be available for inspection by either the Panel or the Technical Assurance Agent.

The total burden on each secondary winding of a VT shall not exceed the rated burden of such secondary winding.

5.1.3 Monitoring of Voltage Transformers

Monitoring facilities for voltage transformers shall be provided for phase failure of any one or combination of phases¹⁰.

The phase failure alarm shall remain active so long as the fault condition exists.

The phase failure alarm must be dedicated to the monitoring of voltage transformers and not be combined with any other monitoring of prevailing conditions (such as an alarm monitoring for the condition where there is current being seen by the Meter but no voltage).

¹⁰ Where the supply to an Outstation is via the measurement transformers only, and in the event that all phases fail, the Outstation shall flag an Outstation supply failure in accordance with Section 5.5.

[P478] Meters combining integral Outstations shall provide for the data to be identified with an alarm indicating phase failure, tagged to the relevant Demand Period(s) and shall be reported via on-line communications and the local Interrogation Unit to the CDCA, ~~or~~ Data Collector or Data Service, as the case may be.

[P478] For separate Outstations, an alarm may be used which shall incorporate a time delay feature so as to avoid spurious operation. A spare channel on the Outstation or any other available means shall be used to transmit the alarm and shall be reported via on-line communications and the local Interrogation Unit to the CDCA, ~~or~~ Data Collector or Data Service, as the case may be.

5.1.4 Measurement Transformers Installed on Existing Circuits

Where circuits, other than those newly installed, are to be metered to this Code of Practice and where the installed measurement transformers do not comply fully with clauses 5.1.1 & 5.1.2, then such measurement transformers may be used providing the requirements in clauses 4.3.1 and 5.1.3 are met.

5.2 Testing Facilities

Separate testing facilities shall be provided for the main Meters and for the check Meters of each circuit, which enables such Meters to be routinely tested and/or changed safely with the circuit energised. The test facilities shall be nearby the Meters involved.

5.3 Meters

The Meters may be either static or induction disc types.

For each circuit main and check Active Energy Meters shall be supplied. These Meters shall meet the requirements of either BS EN/IEC 62053-22 class 0.5S or BS EN 50470-3 class C, or BS EN/IEC 62053-11 class 0.5 except where the overall accuracy as defined in clause 4.3.1 is required in the range "Below 5% to 1%" of Rated Measuring Current. Subject to the agreement of the Panel or Registrant where system or plant conditions permit either the Import or Export Meters may be omitted.

All Meters shall be set to the actual primary and secondary ratings of the measurement transformers and the actual ratios displayed on the display or nameplate of the Meter.

Active Energy Meters provided for the metering of supplies to customers shall be in accordance with Schedule 7 of the Electricity Act 1989.

For each circuit only main Reactive Energy Meter(s) need be supplied. The Reactive Energy Meters shall meet the requirements of BS EN/IEC 62053-23 class 3.0.

For existing metering installations a Reactive Meter connected in a PARh Meter configuration may be retained.

Active Energy Meters shall be configured such that the number of measuring elements is equal to or one less than the number of primary system conductors and matches the configuration provided for in clause 5.1.

All Meters shall be labelled or otherwise be readily identifiable in accordance with Appendix B.

All Meters shall include a non-volatile Meter Register of cumulative energy for each measured quantity. The Meter Register(s) shall not roll-over more than once within the normal Meter reading cycle.

Meters which provide data to separate Outstations shall for this purpose provide an output per measured quantity.

[P478] For Meters using electronic displays due account shall be given to the obligations of the CDCA₂ or other Data Collectors or Data Service to obtain Meter readings. For example, where a Metering System is employed on multiple circuits, a Voltage Selector Relay or other similar method should be used to maintain the Meter display in the event of a circuit being de-energised where this is reasonably practical.

Fusing shall be placed as close as practicable to the VT. In addition, means of isolation shall be provided locally for each Meter, any additional burden and their associated test facilities in accordance with Appendix C.

5.4 Displays and Facilities for Registrant or Supplier Information

5.4.1 Displays

The Metering Equipment shall display the following primary information (not necessarily simultaneously):

- (i) Mandatory Displays
 - (a) Measured quantities as per clause 4.1.1;
 - (b) Current time (“UTC”) and date;
 - (c) Measurement transformer ratios (see clause 5.3); and
 - (d) Any compensation factor which has been applied for measurement transformer errors and/or system losses, where this is a constant factor¹¹ applied at security level 3 (i.e. where the Meter is combined with the display and/or Outstation).

Metering Equipment shall also be capable of displaying the following information, as specified by the Registrant.

- (ii) Display capabilities
 - (a) Maximum Demand (MD) for kW or MW as appropriate per programmable charging period i.e. monthly or statistical review period;

¹¹ N.B. This excludes cases where a dynamic range of compensation factors have been applied.

- (b) Maximum Demand (MD) for kVA or MVA as appropriate per programmable charging period i.e. monthly or statistical review period;
- (c) Twice the kWh advance or MWh advance as appropriate since the commencement of a current Demand Period (i.e. kW or MW rising demand);
- (d) Twice the kVAh advance or MVAh advance as appropriate since the commencement of a current Demand Period (i.e. kVA or MVA Switchgear demand);
- (e) Cumulative MD;
- (f) Number of resets; and
- (g) Multi-rate display sequence as specified by the Registrant with a minimum of 8 rates selectable over the calendar year

MD shall be resettable at midnight of the last day of the charging period and for part chargeable period demands. If a manual reset button is provided then this shall be sealable.

5.4.2 Facilities

The Metering Equipment shall be capable of providing the following information locally to the Customer or Registrant configured to their requirements taking account of the measured quantities (see clause 4.1.1):

- (i) For Active energy in MWh or kWh as appropriate (Import and Export), reactive energy in Mvarh or kVARh as appropriate (Import and Export) – if volt-free contacts are used, then these should use a pulse rate at full load of at least 1000 per Settlement Period with a nominal duration of 80ms per pulse; and
- (ii) A 30 minute reset pulse, and if volt-free contacts are used then this pulse should be within a tolerance of $\pm 0.1\%$ of the Demand Period from the volt-free contacts with a minimum duration of 80ms.

5.5 Outstation

One Outstation System shall be provided which can be interrogated by Settlement Instations. The Outstation system shall comprise either a single separate Outstation or the use of Meters with integral Outstations (i.e. a main or check Meter storing its own data).

Where one or more separate Outstations are provided each Outstation shall store the main and check Meter data for one or more circuits up to a Maximum Aggregated Capacity of 100 MVA. Separate Outstations storing data from a number of different circuits may be cascaded on to one Communication Line.

Metering Systems comprising Meters with integral Outstations need not store data from the associated main or check Meter providing that each Outstation has separate communications.

For Metering Systems located Offshore at Offshore Power Park Modules duplicate Outstation Systems with separate Communication Lines shall be provided. Main and check data shall be accessible using either of the separate Communication Lines. A single point of failure in the communication path between an instation and an Outstation shall not prevent access to main and check metering data stored in required Outstations. Appendix F shows some examples of arrangements for Offshore Power Park Modules.

The Outstation data shall be to a format and protocol approved by the Panel in accordance with BSCP601.

The Outstation shall have the ability to allow the metering data to be read by instations other than the Settlement Instation provided the requirements of clause 7 of this Code of Practice are satisfied.

Facilities shall be provided to select a relevant demand period from one of the following values:-

30, 20, 15, 10 and 5 minutes with in each case one demand period ending on the hour.

Normally metering data will be collected by the Settlement Instations by a daily interrogation, but repeat collections of metering data shall be possible throughout the Outstation data storage period.

Outstations, that are not exclusive to one circuit, shall be fitted with an auxiliary terminal that provides for the Outstation's energisation for remote interrogation purposes. The supply to the auxiliary terminal shall be free of switches and secure, and may be provided from the measurement VT as long as it is separate from the potential measurement circuits at source.

Where a separate modem associated with the Outstation System is used, then it shall be provided with a separately fused supply either from a secure supply or from a measurement VT. Alternatively, line or battery powered modem types may be used.

Where a measurement VT source is used and the Outstation System is storing data for more than one circuit, a VT selection relay scheme involving each circuit shall be provided.

[P478] Preferably, the Outstation shall be able to continue all normal functions for a period of 120 hours after a supply failure. Outstations not providing this facility must in the event of a supply failure transmit an alarm signal via online communications and the local Interrogation Unit to the CDCA_ ~~or~~ Data Collector or Data Service, as the case may be.

The Outstation shall not convert PARh metering data to vars.

5.5.1 Data Storage

Data storage facilities for metering data shall be provided as follows:-

- (i) A storage capacity of 48 periods per day for a minimum of 90 days for all Demand Values.

- (ii) The stored Demand Values shall be integer values of kW/MW or kvar/Mvar as appropriate, or pulse counts, and have a resolution of better than $\pm 0.1\%$ (at full load);
- (iii) The accuracy of the energy values derived from Demand Values shall be within $\pm 0.1\%$ (at full load) of the amount of energy measured by the associated Meter;
- (iv) The value of any energy measured in a Demand Period but not stored in that Demand Period shall be carried forward to the next Demand Period;
- (v) Where a separate Outstation is used, cumulative register values shall be provided in the Outstation which can be set to match and increment with the Meter Registers;
- (vi) In the event of an Outstation supply failure, the Outstation shall protect all data stored up to the time of the failure, and maintain the time accuracy in accordance with clause 5.5.2;
- (vii) Partial Demand Values, those in which an Outstation supply failure and/or restoration occurs, and zero Demand Values associated with an Outstation supply failure, shall be marked so that the Settlement Instation can identify them;
- (viii) To cater for continuous supply failures, the clock, calendar and all data shall be supported for a period of 10 days without an external supply connected;
- (ix) Any "read" operation shall not delete or alter any stored metered data; and
- (x) An Outstation shall provide all of the metered data stored from the commencement of any specified date upon request by the Settlement Instation.

5.5.2 Time Keeping

- (i) The Outstation time shall be set to Co-ordinated Universal Time (UTC). No switching between UTC and British Summer Time (BST) shall occur for Settlements data storage requirements.
- (ii) Time synchronisation of the Outstation shall only be performed by communication with the Settlement Instation.
- (iii) The overall limits of error for the time keeping allowing for a failure to communicate with the Outstation for an extended period of 10 days shall be:-
 - (a) the completion of each Demand Period shall be at a time which is within ± 10 seconds of UTC; and
 - (b) the duration of each Demand Period shall be within $\pm 0.1\%$, except where time synchronisation has occurred in a Demand Period.

5.5.3 Monitoring Facilities

Monitoring facilities shall be provided for each of the following conditions and shall be reported, tagged wherever possible to the relevant Demand Period(s), via the local interrogation facility:-

- (i) Error in Outstation functionality;
- (ii) Battery monitoring (where battery fitted); and
- (iii) Interrogation port access which changes data.

In addition all of the above conditions shall be reported as, at minimum, a common alarm indication via the remote interrogation facility.

5.6 Communications

For integral Outstations: Outstation(s) shall provide both local and remote interrogation facilities, from separate ports.

To prevent unauthorised access to the data in the Metering Equipment a security scheme, as defined below and in Appendix D, shall be incorporated for both local and remote access. Separate security levels shall be provided for the following activities:

- (i) Level 1 Password for:

Read-only access to the following metering data, which shall be transferable on request during the interrogation process:

- (a) Outstation ID;
 - (b) Demand Values as defined in clause 4.1.2;
 - (c) Cumulative measured quantities as defined in clause 4.1.1;
 - (d) Maximum Demand (MD) for kW/MW or kVA/MVA as appropriate (as defined by the Registrant) per programmable charging period i.e. monthly or statistical review period;
 - (e) Multi-rate cumulative Active Energy as specified by the Registrant;
 - (f) Measurement transformer ratios, where appropriate (see clause 5.3)
 - (g) Measurement transformer error correction factor and/or system loss factor, where this is a constant factor applied to the entire dynamic range of the Meter and the Meter is combined with the display and/or Outstation;
 - (h) Alarm indications; and
 - (i) Outstation time and date.
- (ii) Level 2 Password for:
 - (a) Corrections to Outstation time and/or date; and

- (b) Resetting of the MD
- (iii) Level 3 Password for:
Programming of:
 - (a) The Displays and Facilities as defined in clause 5.4;
 - (b) Measurement transformer ratios, as appropriate (see clause 5.3);
 - (c) Measurement transformer error correction factor and/or system loss factor, where this is a constant factor applied to the entire dynamic range of the Meter and the Meter is combined with the display and/or Outstation; and
 - (d) The Passwords for levels 1, 2 and 3;

In addition it shall be possible to read additional information within the Metering Equipment to enable the programmed information to be confirmed.

- (iv) Level 4 Password for¹²:
 - (a) Calibration of the Metering Equipment;
 - (b) Setting the measurement transformer ratios, where appropriate (see clause 5.3);
 - (c) Setting the measurement transformer error correction and/or system loss factors where this is other than a single factor; and
 - (d) Programming the level 3 Password and the level 4 Password, if appropriate.

In addition to the functions specified for each level it shall be feasible to undertake functions at the preceding level(s). E.g. at level 3 it shall also be possible to carry out the functions specified at levels 1 and 2. This need not apply at level 4 when access is obtained via removing the cover. Different Passwords shall be utilised for each level, which shall only be circulated in accordance with the relevant BSC Procedure.

For separate Outstations: A Password shall be required to read or change any data.

5.6.1 Local Interrogation

An interrogation port shall be provided for each Outstation which preferably shall be an opto port to BS EN/IEC 62056-21, and with a serial protocol such as BS EN/IEC 62056-21, for the following purposes:-

- (i) Commissioning, maintenance and fault finding;
- (ii) Transfer of metering data and alarms; and
- (iii) Time setting.

¹² These may be facilitated by the breaking of a seal.

5.6.2 Remote Interrogation

Remote interrogation facilities shall be provided with error checking of the communications between the Outstation System and the Settlement Instation.

Interrogation of an Outstation shall be possible using one of the following media:

- (i) Switched telephone networks e.g. PSTN or CTN;
- (ii) Public data networks e.g. PSN;
- (iii) Radio data networks e.g. Paknet or any equivalent;
- (iv) Customer own network;
- (v) Mains signalling / power line carrier;
- (vi) Low power radio;
- (vii) Satellite; or
- (viii) Cable TV.

In addition any further media may be used as approved by the Panel.

The actual media employed shall be in accordance with the requirements of the CDCA for CVA Metering Systems and the Supplier for SVA Metering Systems.

The data shall be to a format and protocol approved by the Panel in accordance with BSCP601.

5.7 Sealing

All SVA Metering Equipment shall be sealed in accordance with the Retail Energy Code Meter Operation Code of Practice Agreement¹³.

All CVA Metering Equipment shall be capable of being sealed in accordance with BSCP06.

5.8 Single Line Diagram

The following BSC Parties shall create, or secure the creation of, a Single Line Diagram (SLD) for all High Voltage (HV) and Extra High Voltage (EHV) connected sites, and any site, irrespective of its connection voltage, that requires a SVA Meter Operator Agent to submit a Complex Site Supplementary Information Form for a SVA Metering System ID.

¹³ The Meter Operation Code of Practice Agreement is an agreement between Public Distribution System Operators and SVA Meter Operator Agents in accordance with the Retail Energy Code.

SLDs shall be created¹⁴ by the:

- NETSO for Grid Supply Points and Transmission System Boundary Points, including Interconnectors;
- LDSO for Distribution System Connection Points and Distribution System Boundary Points, including Interconnectors; or
- Registrant for Transmission System or Distribution System connected Customer or Generator networks, including Complex Sites.

The SLD shall include:

- the Boundary Point(s) and/or System Connection Point(s), including the location of each Defined Metering Point(s), where different;
- all relevant circuits that have Settlement Metering Equipment that is, or is to be, registered for Settlement purposes and the physical location of the Settlement Metering Equipment (i.e. Actual Metering Point(s)). This includes Metering Equipment located within a Licence Exempt Distribution Network (private network) in an HV/EHV connected site or any Complex Site, irrespective of its connection voltage;
- accuracy classes of all Settlement measurement transformers; and
- the available ratio(s) of all Settlement measurement transformers and, where multi-ratio, the ratio selected.

An SLD shall be created, or updated, for:

- new HV and EHV connected sites;
- new connections, irrespective of that connection voltage, at existing HV and EHV connected sites;
- existing HV and EHV connected sites with existing CVA Boundary Point Settlement Metering Equipment where any new CVA Settlement Metering Equipment, located within a Licence Exempt Distribution Network (private network), is to be registered for Settlement purposes;
- any site, irrespective of its connection voltage, that requires a SVA Meter Operator Agent to submit a Complex Site Supplementary Information Form for a SVA Metering System ID;
- material changes to any registered, or to be registered, Settlement measurement transformers (i.e. replacement of current transformers and/or voltage transformers (on a like for like basis or otherwise), or changes to the ratio selected, where multi-ratio, for existing current transformers and/or voltage

¹⁴ Where an SLD is not created by the BSC Party responsible, that BSC Party is responsible for securing an SLD from the relevant network owner.

transformers). **Note:** Material changes to Settlement Metering Equipment may impact Metering Dispensations; and

- where Settlement Metering Equipment for a circuit is de-registered¹⁵ and other existing Settlement Metering Equipment is still required for an HV or EHV site or Complex Site.

The relevant BSC Party shall provide a copy of the SLD in accordance with the relevant BSC Procedure. The SLD shall also be made available, on request, for inspection by the Panel or Technical Assurance Agent.

6. ASSOCIATED FACILITIES

6.1 Interrogation Unit

The Operator may interrogate the Outstations using an Interrogation Unit (IU). The Interrogation Unit may be used for programming, commissioning, maintenance/fault finding and when necessary the retrieval of stored metering data. The data retrieved by the Interrogation Unit shall be compatible with the Settlement Instation.

6.2 Additional Features

Additional features may be incorporated within or associated with the Metering Equipment provided but these shall not interfere with or endanger the operation of the Settlement process.

7. ACCESS TO DATA

Access to metering data shall be in accordance with the provisions of the Code and the BSC Procedures referred to therein. Such access must not interfere with or endanger the security of the data or the collection process for Settlement purposes.

Access to stored metering data in Outstations shall also be the right of the Registrant and any party who has the permission of the Registrant.

¹⁵ For example, where: Metering Equipment located within a Licence Exempt Distribution Network (private network) is to be de-registered and it is not the Boundary Point Metering Equipment; Metering Equipment that is not related to the last Boundary Point or Systems Connection Point is to be de-registered; an Associated Distribution System (ADS) is to be formed and the original Boundary Point Metering Equipment is to be de-registered.

APPENDIX A: DEFINED METERING POINTS

For transfers of electricity between the following parties the Defined Metering Point (DMP) shall be at one of the following locations:-

1. For transfers between the Transmission System and a Distribution System operated by a Licensed Distribution System Operator where no other Party(s) are connected to the busbar, the DMP shall be at point(s) of connection to the Transmission System
2. For transfers between the Transmission System and a Distribution System operated by a Licensed Distribution System Operator where other Party(s) are connected to the busbar, the DMP shall be at the circuit connections to that Distribution System operated by a Licensed Distribution System Operator.
3. For transfers between the Transmission System and more than one Distribution System operated by a Licensed Distribution System Operator connected to the same busbar, the DMP shall be at the circuit connections of each Distribution System operated by a Licensed Distribution System Operator to such busbar.
4. For transfers between Distribution Systems operated by Licensed Distribution System Operators, not including a connection to the Transmission System, the DMP shall be at the point(s) of connection of the two Distribution Systems operated by Licensed Distribution System Operators.
5. For transfers between the Transmission System and:-
 - (i) Generating Plant, the DMP shall be at the point(s) of connection of the Generating Plant to the Transmission System.
 - (ii) An Offshore Power Park Module(s) comprising a single BM Unit, the DMP shall be at the point(s) of connection of the Offshore Power Park Module to the Transmission System. A Party may install Metering Equipment at either:
 - the DMP; or
 - a point or points on the Offshore Platform, other than the DMP. Such point or points shall be the Actual Metering Point for the purposes of this Code of Practice.
6. For transfers between a Distribution System operated by a Licensed Distribution System Operator and Generating Plant, the DMP shall be at the point(s) of connection of the generating station to the Distribution System operated by a Licensed Distribution System Operator.
7. For transfers between a Distribution System operated by a Licensed Distribution System Operator and a Customer, the DMP shall be at the point(s) of connection to the Distribution System operated by a Licensed Distribution System Operator.
8. For transfers between the Transmission System and a Customer, the DMP shall be at the point(s) of connection to the Transmission System.
9. For transfers between the Transmission System, or a Distribution System operated by a Licensed Distribution System Operator, and an External System the DMP shall be at the

Formatted: Font: 10 pt, Bold, Condensed by 0.15 pt

point(s) of connection of that External System to the Transmission System or to the Distribution System operated by a Licensed Distribution System Operator.

10. For transfers between an Offshore Transmission System (or Offshore Transmission System User Assets) and a Distribution System operated by a Licensed Distribution System Operator, the DMP shall be at the point(s) of connection to the Distribution System operated by a Licensed Distribution System Operator.

Formatted: Font: 10 pt, Bold

APPENDIX B: LABELLING OF METERS FOR IMPORT AND EXPORT

1 A standard method of labelling Meters, test blocks, etc is necessary and based on the definitions for Import and Export the required labelling shall be as follows.

2 **ACTIVE ENERGY**

Meters or Meter Registers shall be labelled "Import" or "Export" according to the diagram "Figure 1".

3 **REACTIVE ENERGY FOR METERS REGISTERED IN CMRS**

Within the context of this code the relationship between Active Energy and Reactive Energy can best be established by means of the power factor. The following table gives the relationship:-

Flow of Active Energy	Power Factor	Flow of Reactive Energy
Import	Lagging	Import
Import	Leading	Export
Import	Unity	Zero
Export	Lagging	Export
Export	Leading	Import
Export	Unity	Zero

Meters or Meter Registers for registering Import Reactive Energy should be labelled "Import" and those for registering Export Reactive Energy should be labelled "Export".

4 REACTIVE ENERGY FOR METERS REGISTERED IN SMRS

Within the context of this code the relationship between Active Energy and Reactive Energy can best be established by means of the power factor. The following table gives the relationship:-

Flow of Active Energy	Power Factor	Flow of Reactive Energy	Additional Information
Import	Lagging	Import	Associated with Active Import
Import	Leading	Export	Associated with Active Import
Import	Unity	Zero	n/a
Export	Lagging	Export	Associated with Active Export
Export	Leading	Import	Associated with Active Export
Export	Unity	Zero	n/a

Meters or Meter Registers for registering Import Reactive Energy should be labelled "Import" and those for registering Export Reactive Energy should be labelled "Export" but with additional information for reactive Meters or Registers identifying the Active Meter or Register it is associated with.

FIGURE 1 IMPORT AND EXPORT ACTIVE ENERGY FLOWS CONVENTION

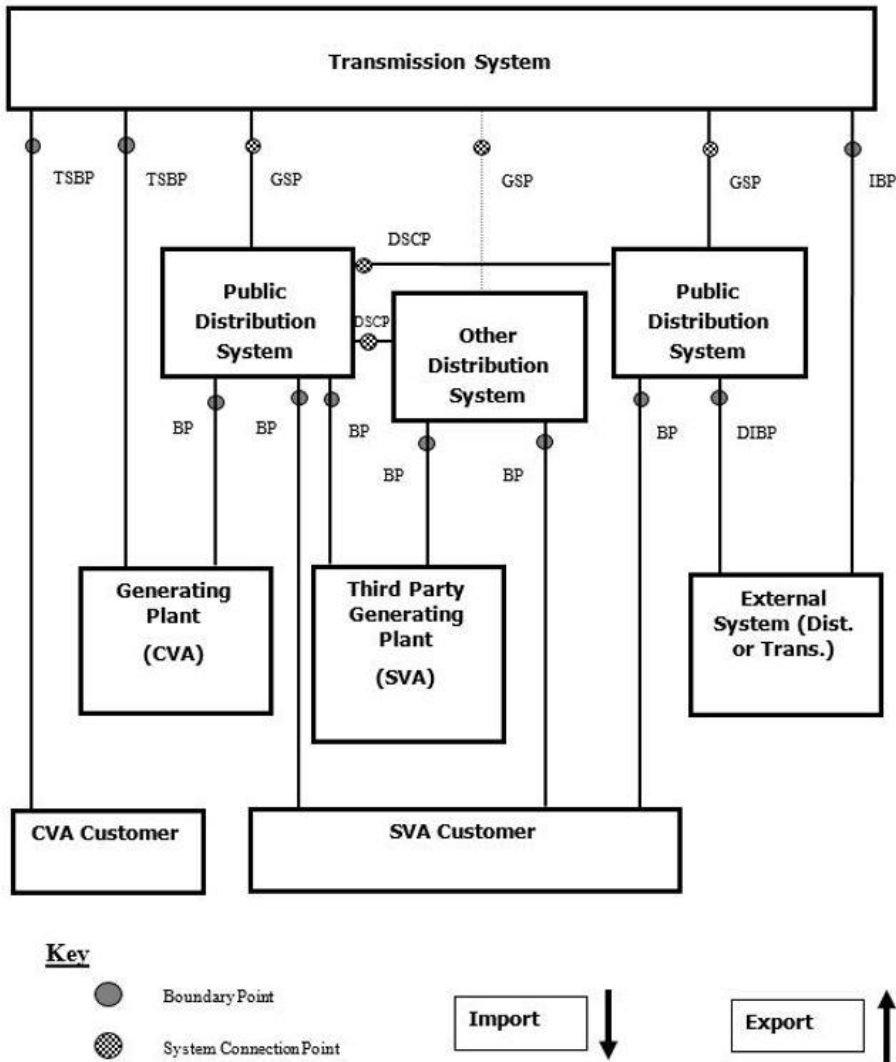

Import / Export Energy Flow Convention for the labelling of Meters

Import metering measures energy flows away from the Transmission System.
 Export metering measures energy flows towards the Transmission System.
 Energy flows between Distribution Systems is by bilateral agreement.

Formatted: Font: 10 pt, Bold, Condensed by 0.15 pt

Key to abbreviations used in Import / Export Diagram

O	Metering Point
BP	Boundary Point
DIBP	Distribution Interconnector Boundary Point
DSCP	Distribution System Connection Point
GSP	Grid Supply Point
IBP	Interconnector Boundary Point
SCP	System Connection Point
TSBP	Transmission System Boundary Point

Formatted: Font: 10 pt, Bold

APPENDIX C: FUSING

The following diagrams show typical arrangements for the fusing requirements of this Code of Practice, where a Settlement voltage transformer is provided for each circuit. The diagrams are non-exhaustive and are provided for reference only.

Figure 1: Fusing arrangements for cable runs of less than 30 metres distance between source fusing and local means of isolation^{16 17}.

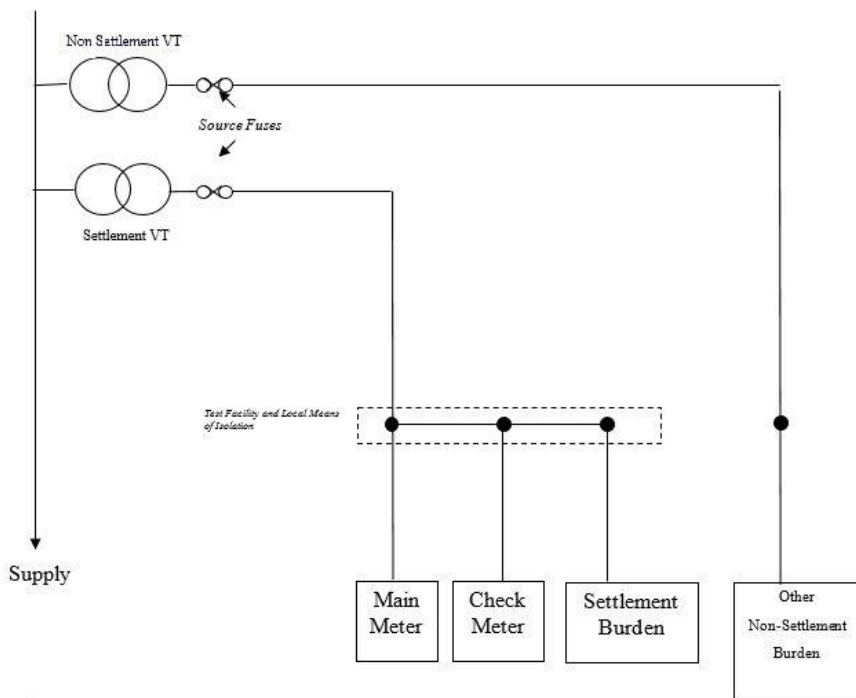

Note:

Source fusing and local means of isolation shall include the use of solid links in the potential return conductor.

The boundary between Meter Operator Equipment and the Transmission/Distribution System Operator is between the local means of isolation and the testing facilities.

¹⁶ Isolation may be provided by the use of solid links or fuses and may be placed on either side of the test terminal block. Where fuses are to be used, the additional burden shall be accounted for.

¹⁷ Check Meters and other burden may be supplied via an additional secondary winding of the VT

Figure 2: Fusing arrangements for cable runs of more than 30 metres distance between source fusing and local means of isolation^{18 19}.

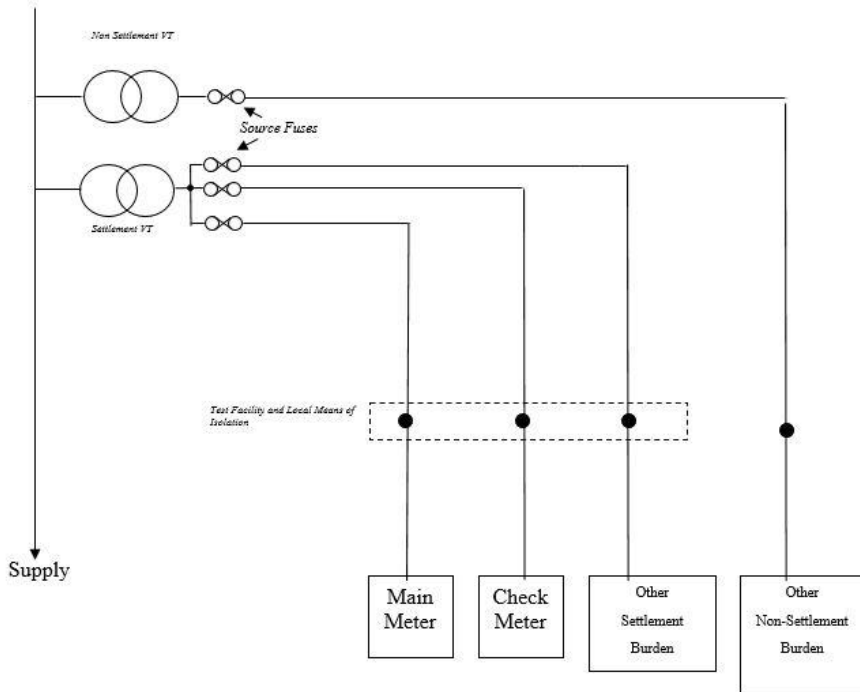

¹⁸ Local isolation may be provided by the use of solid links or fuses and may be placed on either side of the test terminal block. Where fuses are to be used, the additional burden shall be accounted for.
¹⁹ Check Meters and other burden may be supplied via an additional secondary winding of the VT.

Formatted: Font: 10 pt, Bold, Condensed by 0.15 pt

APPENDIX D: PASSWORDS

The Passwords specified in clause 5.6 shall be subject to the following additional requirements:

- (i) The communications protocol employed shall ensure that the Password offered determines the level of access to the data within the Metering Equipment.
- (ii) A counter to log the number of illegal attempts (i.e. Password comparison failures) to access Metering Equipment via the local and remote ports shall be incorporated into the log-on process. This counter shall reset to zero at every hour change (i.e. 0100, 0200, etc).
- (iii) If the counter reaches 7, then access is prohibited at all levels until the counter resets at the next hour change.

Formatted: Font: 10 pt, Bold

APPENDIX E: GUIDANCE FOR THE USE OF MULTI CORE METERING CABLES

Multi core cables are predominantly used to provide CT and VT signals to the Meter. However such arrangements may cause additional errors that are not readily apparent to the Metering System designer. This guidance provides information that should be considered when using multi core cables for metering, particularly if used over long cable runs.

Consideration shall be given to the cross sectional area of the conductors of multi core cables:

- (i) In CT circuits the cabling resistance is likely to represent an appreciable component of the CT burden and care should be taken to ensure that the CT overall burden is not exceeded;
- (ii) For the VT circuits, cabling and fuses introduce volt drop errors. Fuses with a low current rating tend to have a relatively high resistance value and are variable from fuse to fuse. Careful selection of fuses, fuse holders and the doubling of cores can be used to mitigate these effects.

The proximity of CT and VT signals in multi-core cables can cause errors due to capacitive coupling from the voltage to the current circuits. The effect of this coupling is more prevalent at low loads and with long cable runs, in particular with 1 amp rated CTs. One possible symptom of this condition is that the Meters may advance under no load conditions (circuit energised but with no load current). This coupling effect may be eliminated by careful allocation of cable core to function, or by running CT and VT signals in separate cables.

APPENDIX F: GUIDANCE FOR THE COMMUNICATION ARRANGEMENTS FOR METERING SYSTEMS LOCATED OFFSHORE AT OFFSHORE POWER PARK MODULES

In this Code of Practice, it is a minimum requirement that a set of Measurement Transformers be provided which are dedicated for Settlement use and may be used for both the main and the check Meter that are required for each² measured circuit.

Where one or more Outstations that are not integral with an associated Meter are provided, each Outstation shall store the main and check Meter data for one or more circuits up to a Maximum Aggregated Capacity of 100 MVA. Separate Outstations storing data from a number of different circuits may be cascaded on to one Communication Line.

Metering Systems comprising Meters with integral Outstations need not store data from the associated main or check Meter providing that each Outstation has separate communications.

For Metering Systems located Offshore measuring Offshore Power Park Module export and import, main and check data shall be accessible using either of separate Communication Lines, and a single point of failure in the communication path between an instation and an Outstation shall not prevent access to main and check metering data stored in required Outstations. For Outstations which are not integral with an associated Meter, both main and check Meter data should be stored on duplicate Outstations each having at least one independent Communication Line. Outstations storing data from different circuits may be cascaded on to one Communication Line as if they were parts of one Outstation.

Where shared communication network components are used, for example copper wire or optical fibre and associated connectors, routers and switches with Internet Protocol (IP) addressing of end points, the Registrant should ensure that the requirement for independent communication lines is achieved by the existence of sufficient duplication and redundancy to ensure that two or more independent end to end communication paths exist between the instation and Outstation. The following examples show some possible arrangements for guidance, using an optical fibre cable in which at least two of the fibres are independently allocated to Settlement metering data in order to satisfy the requirement for separate Communication Lines.

Example 1 Meters with integral Outstations using optical fibre communications

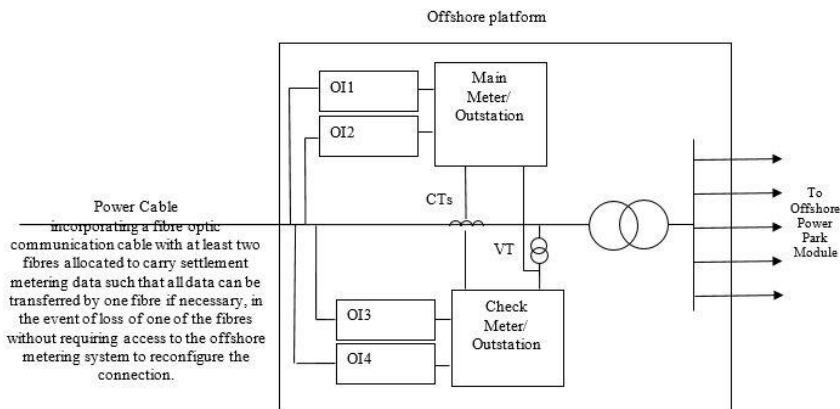

In this example, there is a single power cable connecting the Offshore Power Park Module to the mainland which incorporates a fibre optic communication cable.

The communication cable contains multiple optical fibres and is used amongst other things to provide communications between the Settlement instation and the Outstations which are located on the offshore platform. Sufficient optical fibres should be allocated to the Settlement communications to ensure that main and check data can continue to be collected automatically without requirement for physical access to the Offshore Metering Equipment in the event of failure of any individual allocated fibre.

The Meters have integral Outstations each storing main and check data separately. If each Outstation stored data from both main and check Meters then only two Communication Lines would be necessary (OI1 and OI3 or OI2 and OI4) as the failure of either one would not prevent access to both main and check metering data (as in Example 2). However in this example this is not the case therefore additional Communication Lines are required. Each Meter has two optical interfaces (OI1, OI2 and OI3, OI4) and each has a unique IP address.

There are two Outstations and four Communication Lines.

This example shows a single optical cable being used but would equally apply to multiple cables or any other communications media such as satellite communications or PSTN.

Example 2 Meters with separate Outstations using optical fibre communications

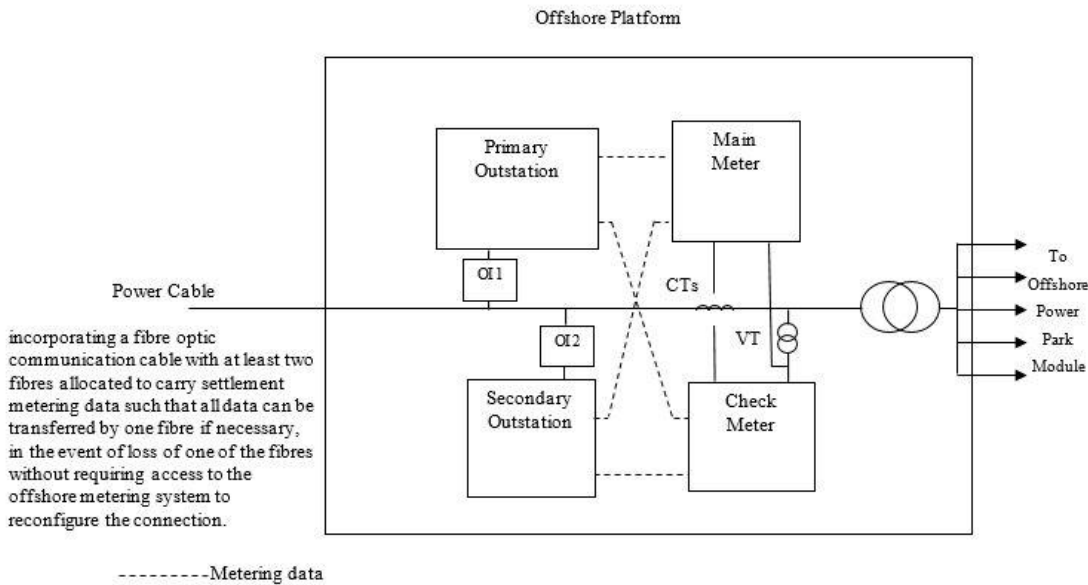

In this example, there is a single power cable connecting the Offshore Power Park Module to the mainland which incorporates a fibre optic communication cable.

The communication cable contains multiple optical fibres and is used amongst other things to provide communications between the Settlement Instation and the Outstations which are located on the offshore platform. Sufficient optical fibres should be allocated to the Settlement communications to ensure that main and check data can continue to be collected automatically without requirement for physical access to the Offshore Metering Equipment in the event of failure of any individual allocated fibre.

The Meters transfer readings to both the separate Outstations and each Outstation has one optical interfaces (OI1 and OI2). Each optical interface has a unique IP address.

There are two Outstations and two Communication Lines.

This example shows a single optical cable being used but would equally apply to multiple cables or any other communications media such as satellite communications or PSTN.

APPENDIX G: GUIDANCE FOR THE USE OF BUSBAR VOLTAGE TRANSFORMERS

In this Code of Practice, it is a minimum requirement that where a set of voltage transformer primary windings connect to a busbar this is only permitted where the following conditions are met:

- a) The busbar is common to the multiple circuits being measured for Settlement purposes;
- b) The busbar cannot be split electrically;
- c) The busbar voltage level is the same voltage level as it is at the DMP;
- d) A voltage transformer is provided with a dedicated secondary winding for the all of the main metering;
- e) A second voltage transformer is provided with a dedicated secondary winding for all of the check metering; and
- f) The total burden on each secondary winding of a voltage transformer shall not exceed the rated burden of such secondary winding.

Where busbars are electrically separate, or can be run split, each separate busbar must have a set of voltage transformers and meet the conditions stated above.

The associated current transformers must be located at the DMP as defined in Appendix A. Where the current transformers are not located at the DMP a Metering Dispensation shall be required, unless the AMP is permitted to be away from the DMP for the purposes of this Code of Practice²⁰. Where the voltage transformers' primary windings do not connect at the same voltage level as it is at the DMP, a Metering Dispensation shall be required.

The following examples show some possible arrangements in simplified single line diagrams for guidance.

Example 1 is for Metering Systems located Offshore, measuring Offshore Power Park Module Export and Import. The voltage transformers' primary windings are to connect electrically to a single busbar and at the same voltage level as the strings of wind turbine generators (WTGs) being measured for Settlement purposes.

²⁰ See Section 4.3.3 and Appendix A 1 and 5 (ii).

Example 1 Offshore wind farms metering at string level on the Offshore platform with a single busbar

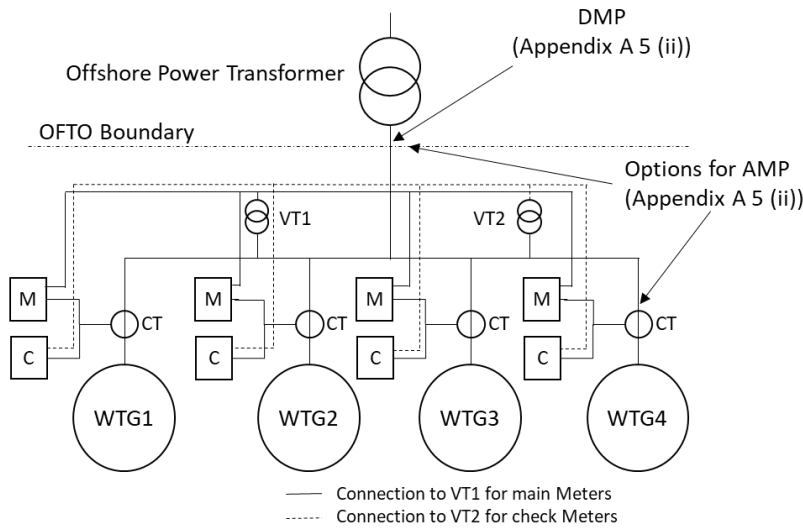

Example 2 is for Metering Systems located Offshore, measuring Offshore Power Park Module Export and Import. The voltage transformers' primary windings connect to each electrically separate busbar and at the same voltage level as the strings of WTGs being measured for Settlement purposes.

Example 2 Offshore wind farms metering at string level on the Offshore platform with electrically split busbars

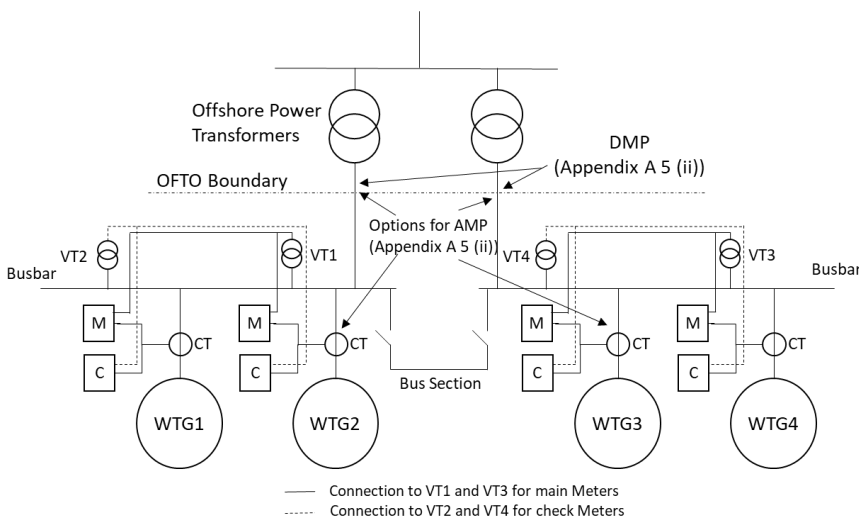

Examples 3 and 4 are for Metering Systems located onshore where the site has a single point of connection but is, or has the potential in the future, to be split into separate parts that are to be traded and settled separately (i.e. under separate MSIDs). Each Metering System shall measure Import and/or Export, and where the voltage transformers' primary windings are connected to the same voltage level as the separate parts of the site and the DMP.

In these examples (3 and 4) a Metering Dispensation shall be required for the AMP not being at the DMP (i.e. the current transformers are installed at the AMP and not the DMP), unless the AMP is permitted to be away from the DMP for the purposes of this Code of Practice²⁰. In this scenario, all voltage transformers shall be compliant with the current version of this Code of Practice. Where any additional circuit is installed against a version of this Code of Practice with different requirements to those specified in 5.1.2 from the original part of the site, each circuit should be metered separately or a Metering Dispensation shall be required.

In Example 3 the site is originally built and split into two parts (e.g. one part for renewable generation and a second part for battery storage), with the option of future expansion. This example could also apply to a single use site that has the option of future expansion, whether or not that future expansion will need to be traded and settled separately from the original part of the site. Example 4 shows an example where future expansion has occurred and there are four parts to the site that require to be traded and settled separately.

Scenarios described in these examples are not exhaustive and can cover other scenarios where multiple Metering Systems are installed behind a single DMP.

Example 3 Onshore metering with two Metering Systems behind a single DMP

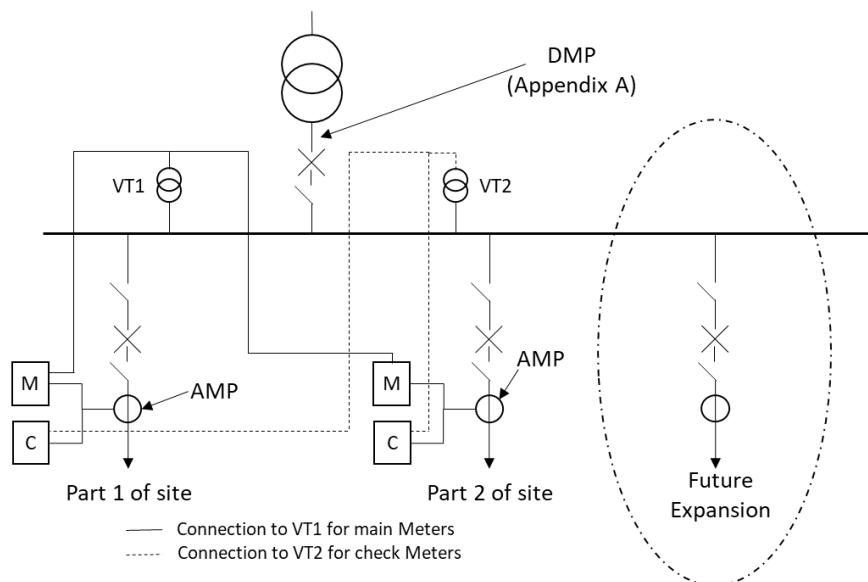

Example 4 Onshore metering with multiple Metering Systems behind a single DMP.

